

# DC BLOCKING CONNECTOR

2.9mm, 7 kHz - 45 GHz, 25 Volts

## SPECIFICATIONS:

Models: 8537KF, 8537KM

**RoHS**  
Compliant

<b>Electrical:</b>	
Frequency Range	7 KHz - 45 GHz
Insertion Loss	
100 KHz - 12.4 GHz	0.50 dB Max.
12.4 - 32 GHz	0.75 dB Max.
32 - 40 GHz	1.00 dB Goal (1.25 dB Max.)
VSWR	
100 - 250 KHz	<1.40:1 Typical
250 KHz - 32 GHz	1.40:1 Max.
32 - 40 GHz	1.50:1 Max.
Impedance	50 Ohms
Working Voltage	25 Volts Max.
Bandwidth (-3 dB)	<7 KHz to >45 GHz
Operating Temp Range	-20°C to +85°C
Minimum Capacitance over Temperature	70kpf
<b>Mechanical:</b>	
2.9mm Connectors	Passivated Stainless Steel
Mates with SMA, 3.5mm and K* Series Connectors as well as SMK IAW MILSTD-348	
Conductors	Gold Plated Beryllium Copper

\* K is a Trademark of Anritsu Corp.

**AEROFLEX**  
A passion for performance.

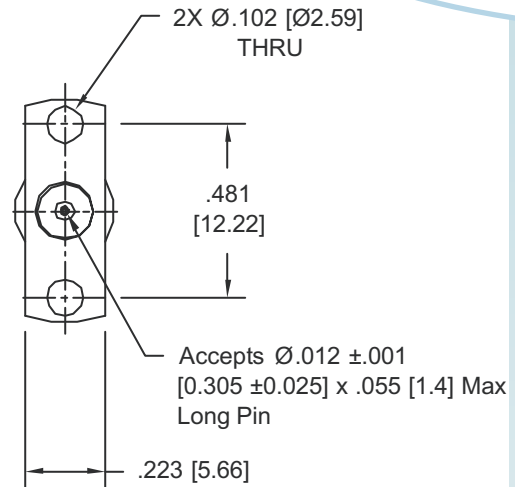

Model Number: **8537KF**  
2.9mm FEMALE

Model Number: **8537KM**  
2.9mm MALE

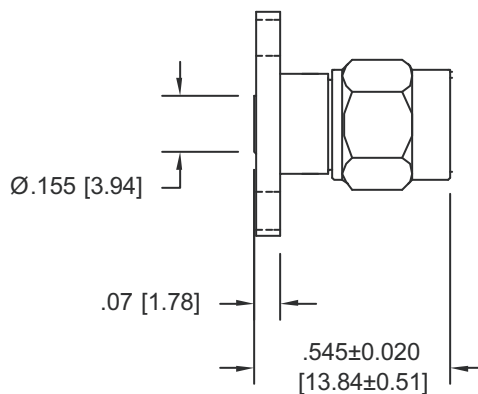
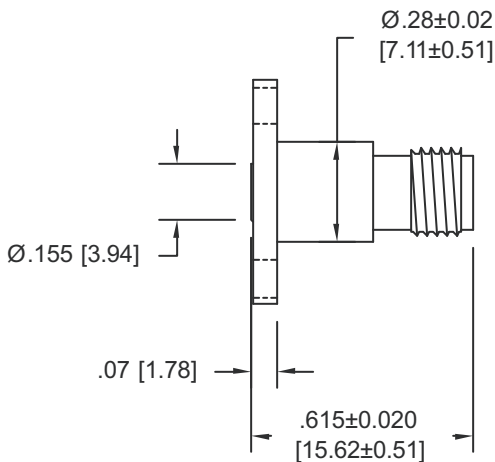

Mounting Surface Should be Flat per Inmet Application Note APPN-1010 and when Tightening Please Follow Method Outlined therein for Proper High Frequency Performance.

Note: Dimensions in Brackets are Expressed in Millimeters and are for Reference Only.

8537: REV C

**AEROFLEX**  
INMET

Aeroflex / Inmet, Inc. • 300 Dino Drive, Ann Arbor, MI 48103 • U.S.A.  
888-244-6638 or 734-426-5553 • FAX: 734-426-5557  
www.aeroflex.com/inmet • inmet-sales@eroflex.com