



A passion for performance.

**GR712RC Dual-Core
LEON 3FT Microprocessor**

**Designed for operation
in harsh environments**

Fault Tolerant architecture

**Guaranteed radiation
performance**

**Real-time multiprocessing
support**

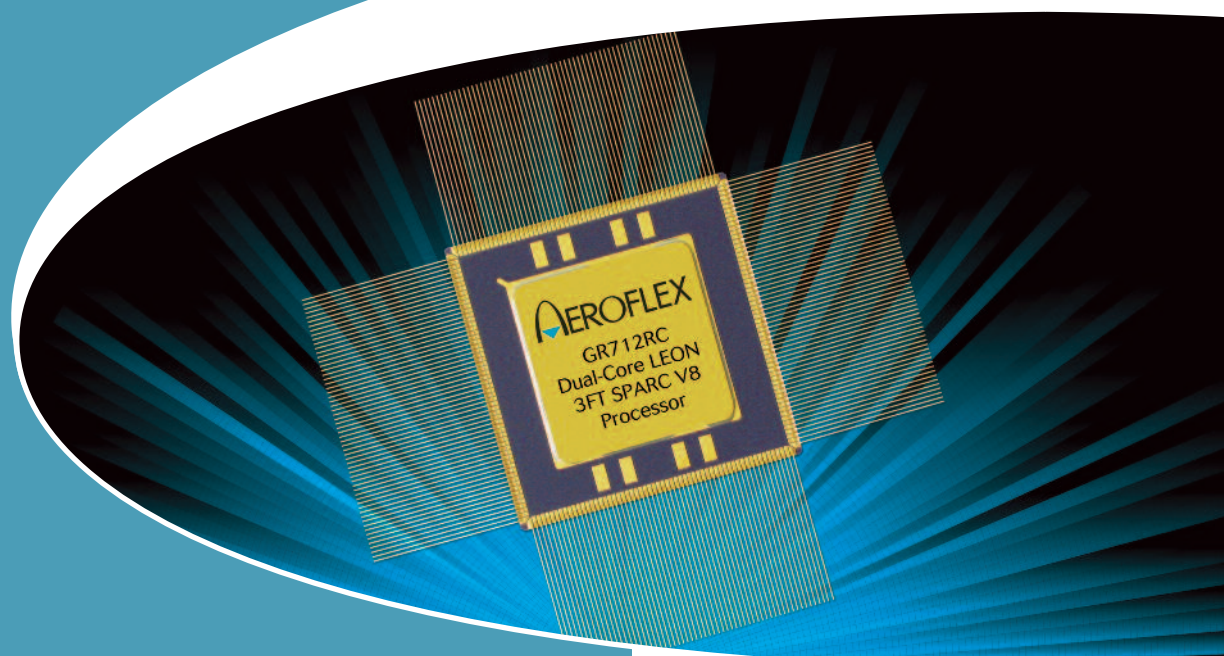

**Dual-Core LEON 3FT
SPARC™ V8 32-Bit
Microprocessor**

It's a fact

Definitions

LEON µprocessor

LEON is a 32-bit CPU micro-processor core, based on the SPARC™ V8 RISC architecture and instruction set. The core is highly configurable, and suitable particularly for system-on-chip (SOC) designs. LEON 3FT is a Fault-Tolerant (FT) version, designed for operation in harsh, radiation-prone environments, and includes functionality to detect and correct single bit upset errors in all on-chip RAM memories.

Definitions

SPARC™ architecture

SPARC (Scalable Processor Architecture) is a RISC (Reduced Instruction Set Computing) architecture developed by Sun Microsystems. SPARC is a registered trademark of SPARC International, Inc., an organization established to create a larger ecosystem for the design by promoting, licensing, and providing conformance testing. As a result, the SPARC architecture is fully open and non-proprietary.

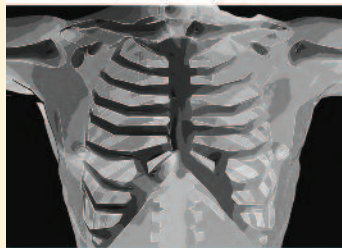
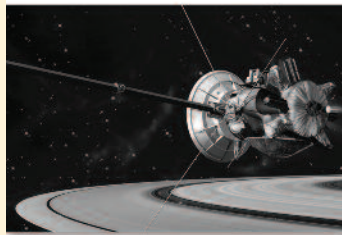

WE OFFER DEVELOPMENT TOOLS AND REAL-TIME OPERATING SYSTEM SUPPORT...

An advantage to working with Aeroflex Gaisler's GR712RC is the extensive library of development tools. Since the GR712RC is SPARC™ V8 compliant, compilers and kernels for SPARC V8 are based on industry-standard development tools. Aeroflex offers a full software development suite including a C/C++ cross-compiler system based on GCC and the Newlib embedded C-library.

The BCC compiler system allows cross-compilation of C and C++ applications for the LEON 3FT family. For multi-threaded applications, SPARC-compliant ports are available for the following operating systems: eCos, RTEMS, Linux, VxWorks, Nucleus, ThreadX, and LynxOS.

To support the software development process, a simulator and a debugger are available. TSIM is a high-performance SPARC-architecture instruction simulator capable of emulating the GR712RC LEON 3FT. GRSIM is a flexible simulation framework for advanced system-on-chip devices based on the AMBA on-chip bus, capable of emulating multi-core LEON 3FT devices. GRMON is a debug monitor for the GR712RC processor. It communicates with the GR712RC debug support unit (DSU) and allows non-intrusive debugging of the complete target system.

...PLUS PROVEN IP

The Aeroflex Gaisler GRLIB IP Library is an integrated set of reusable IP cores, designed for system-on-chip (SOC) development. The IP cores are centered around the common on-chip bus and use a coherent method for simulation and synthesis. The library is vendor independent, with support for different CAD tools and target technologies. A unique plug-and-play method is used to configure and connect the IP cores without the need to modify any global resources.

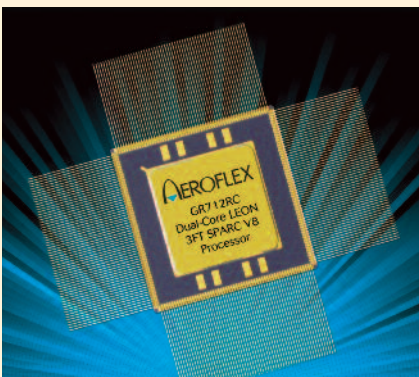

www.aeroflex.com/gaisler +46 31 775 86 50

GR712RC Software Development Tools (Debug)

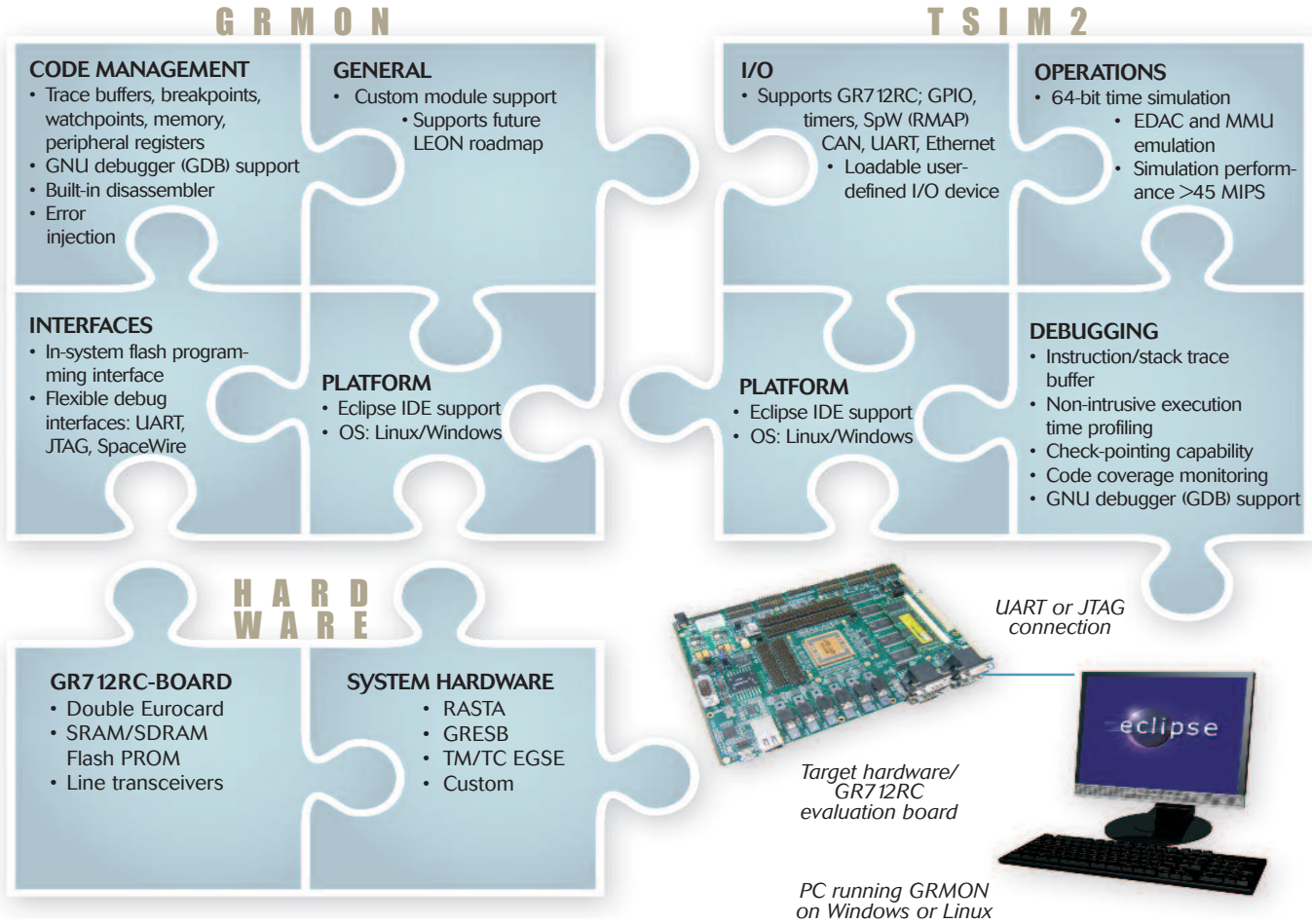

GR712RC Operating Systems Options (RTOS)

Aeroflex Gaisler provides the following operating systems options:

- RTEMS
- eCos
- Nucleus
- LynxOS
- ThreadX
- VxWorks
- Linux

For multiprocessing support, choose between asymmetric multiprocessing (AMP) with RTEMS, or symmetric multiprocessing (SMP) with Linux, VxWorks and eCos.

RTEMS and VxWorks have device drivers for all on-chip functions making them suitable for rapid development of on-board software.



LEON IDE featuring



- Eclipse-based C/C++ integrated development environment
- Code entry, build system, and debugging provided
- Support for debugging on real hardware through GRMON or on a simulator through TSIM
- Support for different toolchains, templates for RTEMS/RCC, BCC, Nucleus, ThreadX, and eCos
- Source-level debugging and disassembly view
- Variables, memory, and register view
- Support for Linux and Windows host platforms

LEON Integrated Development Environment (IDE)

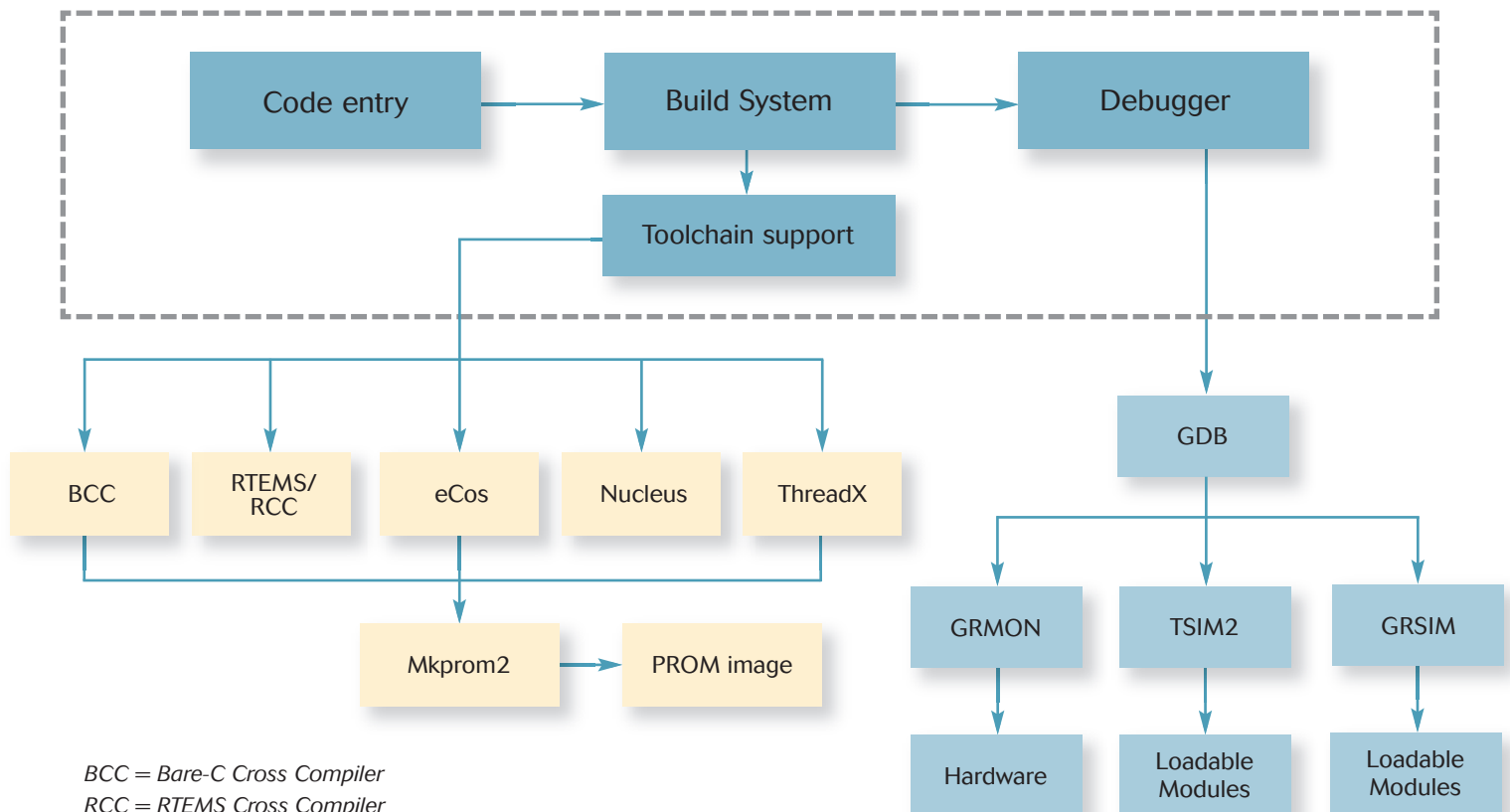

BCC = Bare-C Cross Compiler
 RCC = RTEMS Cross Compiler
 GDB = GNU debugger
 Mkprom2 = Make PROM utility

GR712RC is dedicated to HiRel

GR712RC FEATURES

- Implemented on a 180nm CMOS technology
- Flexible static design allows up to 100MHz clock frequency with external SRAM
- Up to 300 DMIPS throughput
- Dual-core 32-bit SPARC V8 processor
- On-board programmable timers, interrupt controllers
- High-performance dual-precision IEEE-754 FPU
- Power-saving 1.8V core power supply; 3.3V I/O
- Hardened-by-design flip-flops

GR712RC CORES

AMBA bus interconnects a peripheral rich environment:

- 10/100 Base-T Ethernet port
- Six integrated multi-protocol SpaceWire nodes with two supporting the RMAP target protocol in hardware
- Two CAN 2.0 compliant bus interfaces
- Redundant MIL-STD-1553B BC/RT/MT
- CCSDS/ECSS telemetry and telecommand
- Multifunction memory controller with EDAC
- UARTs, GPIO, I2C, SPI, etc.

GR712RC GUARANTEED RADIATION PERFORMANCE / OPERATIONAL ENVIRONMENT

PARAMETER	LIMIT	UNITS
Total Ionizing Dose (TID)	3E5	rads(Si)
Single Event Latchup (SEL)	>118	MeV-cm ² /mg

Proven SEU tolerance with hardened flip-flops and error correction on all on-chip memories.

GR712RC BLOCK DIAGRAM

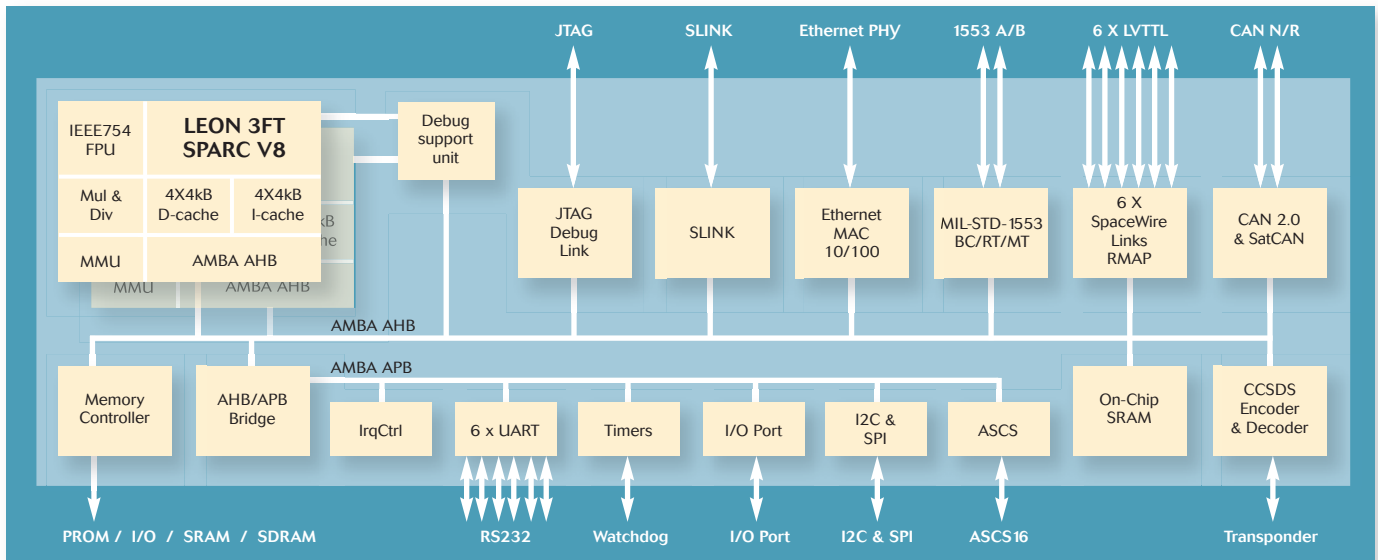

NOTIONAL SINGLE BOARD COMPUTER

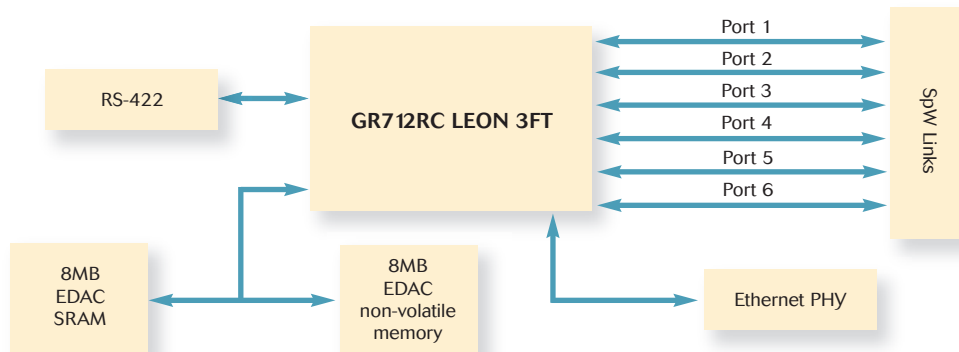

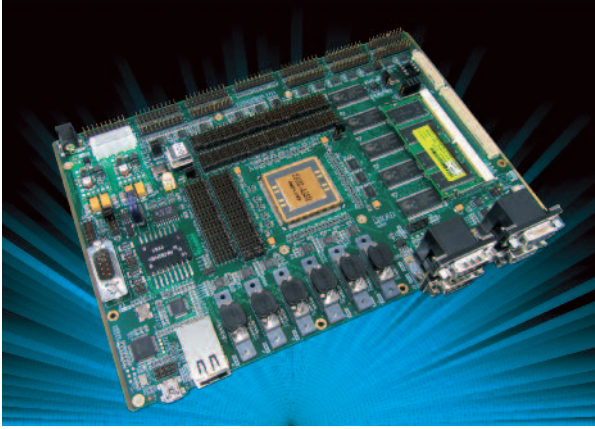

LEON GR712RC 3FT SPARC™ V8 MICROPROCESSOR EVALUATION BOARD

The GR712RC-BOARD evaluation board is capable of running at a system clock speed of 100MHz. The board is a double Eurocard form factor used in a standalone bench-top configuration. The board supports MIL-STD-1553B, 10/100 Base-T Ethernet, six SpaceWire ports capable of running up to 200Mbps/s, two CAN ports, on-board FLASH, SRAM, and SDRAM. USB debug port is also available on-board.

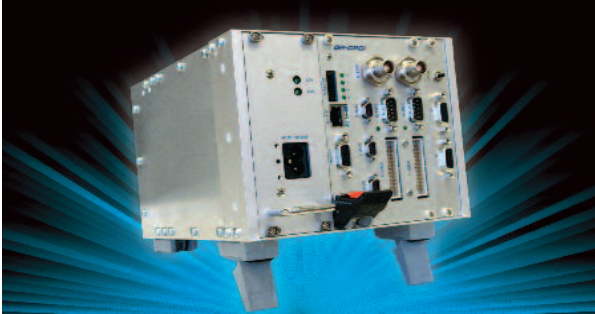

RASTA

The Aeroflex Gaisler implementation of the RASTA (Reference Avionics System Testbed Activity) aims to provide a standardized hardware and software infrastructure for development, prototyping and validation of on-board systems. It allows quick and easy integration of complete systems in a lab environment, using standardized interfaces and connectors. It provides access to LEON 3 technology (through FPGA, ASIC, or products like GR712RC).

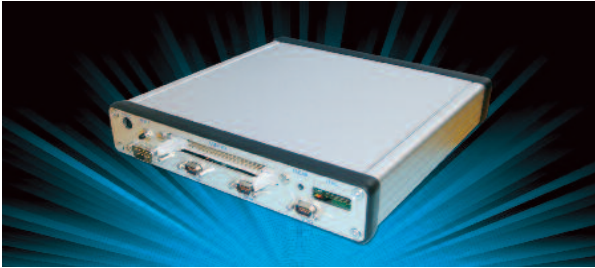

ETHERNET/SPACEWIRE ROUTING BRIDGE

The bridge facilitates rapid development and testing of equipment with SpaceWire interfaces such as GR712RC, providing three bi-directional SpaceWire links with 100 Mbit/s maximum data rate and six virtual links interfaced through TCP sockets over Ethernet. It includes a programmable SpaceWire router.



CCSDS/ECSS TM & TC EGSE

The CCSDS/ECSS Telemetry and Telecommand EGSE (Electrical Ground Support Equipment) provides means for communicating with the telemetry encoder and telecommand decoder implemented in the GR712RC device. It has been designed to support satellite integration and test activities, on-board space segment development, ground segment applications, etc.

Aeroflex Gaisler

WEB SITE www.aeroflex.com/gaisler

TELEPHONE +46 31 775 86 50
800-645-8862

AEROFLEX
A passion for performance.



Our passion for performance is defined by three attributes represented by these three icons: solution-minded, performance-driven and customer-focused.