

## Standard Products

# ACT4430PC / ACT4431SC Superpipelined 64-Bit R4400 RISC Microprocessor Multichip Module

[www.aeroflex.com/Avionics](http://www.aeroflex.com/Avionics)

April 15, 2005



## FEATURES

- ❑ Full militarized MIPS R4400 microprocessor
- ❑ Low power dissipation, 3.3 Volt powered, 64 bit superpipelined RISC R4400 microprocessor
  - Highly integrated CPU with integer unit, FPA, MMU, I&D cache
  - Balanced integer & floating point performance
  - Exploits 2-level instruction-level parallelism
  - No issue restrictions on the instructions used
- ❑ Integer unit
  - 32 entry, 64 bit wide register
  - ALU
  - Dedicated multiplier/divider
- ❑ Super pipelined FPA
  - 32/16 entry 32/64 bit register file in a 32 bit mode
  - 32 entry 64 bit register file in 64 bit mode
  - Supports single and double precision
  - Supports ANSI/IEEE Standard 754-1985
- ❑ Memory management unit
  - 48 entry TLB for fast virtual-to-physical address translation, software managed cntrl regstrs
  - Programmable page sizes from 4K bytes to 16M bytes
  - Total physical address space encompasses 64G bytes
  - One pair of pages per TLB entry, each programable in size from 4K bytes to 16M bytes
- ❑ JTAG boundary scan capability for testing module interconnects
- ❑ Internal 1M byte secondary cache SRAM configured as a split cache with instruction and data sections separate. Can be factory configured as unified.
- ❑ Provides 16 bit ECC on secondary cache data line, 7 bit ECC on tag line
- ❑ Minimum clock rate 50 mHz with no wait states
- ❑ +3.3V (10 Watts max power dissipation) operation is standard
- ❑ Full military operating temperature range of -55°C to +125°C, case temperature
- ❑ Designed to meet military specifications, manufactured and tested in Aeroflex's MIL-PRF-38534 certified facility
- ❑ Designed for Commercial, Industrial and Aerospace Applications
- ❑ Aeroflex-Plainview is a Class H & K MIL-PRF-38534 manufacturer
- ❑ 280-lead CQFP, Flat package (F10)
- ❑ 179-Pin PGA, Plug-In (P10)

## DESCRIPTION

The Aeroflex Plainview ACT4431SC is a full military temperature range 64 bit, super-pipelined RISC microprocessor with 1M Byte of secondary cache memory packaged in a high speed multichip module (MCM). The modules contains the following components:

- (1) R4400SC, a 3.3V powered RISC microprocessor
- (11) SRAMs, 64K by 16
- (3) Buffers and (3) Passive components for phase lock loop operation

A Primary cache only version, the ACT4430PC is available in the same package or 179 pin PGA

(Use with "MIPS R4000 Microprocessor Users Manual"© MIPS 1993)

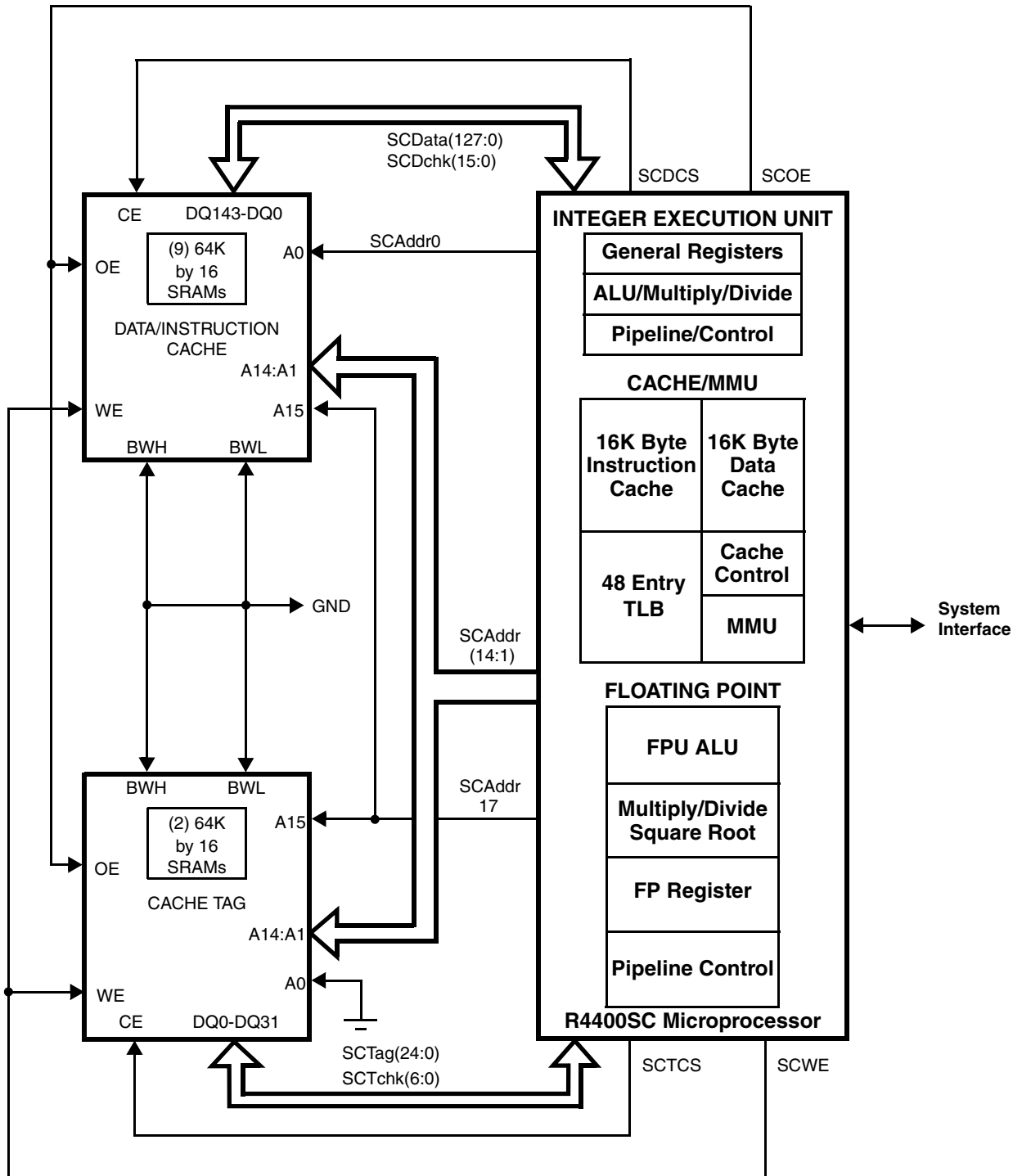

**BLOCK DIAGRAM (SC VERSION)**

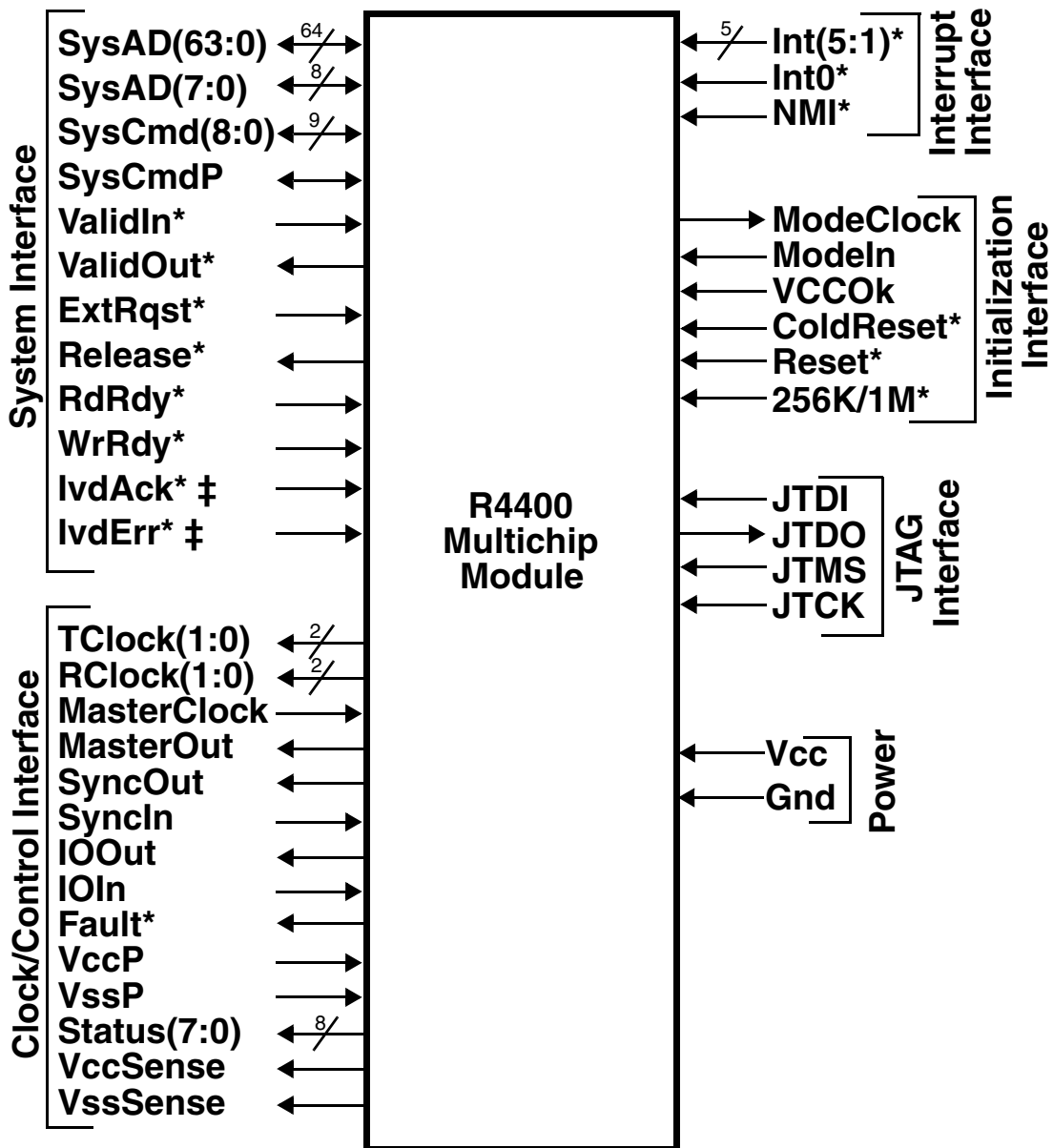

Note: Int(5:1)\* available on ACT4430PC version

‡ lvdAck, lvdErr used in "MC" mode

### MODULE SYMBOLIC INTERFACE CONNECTIONS

## SIGNAL DESCRIPTIONS

### System Interface Signals

SysADy(63:0)	I/O	<b>System address/data bus:</b> A 64 bit address and data bus for communication between the processor and an external agent
SysADC (7:0)	I/O	<b>System address/data check bus:</b> An 8 bit bus containing check bits for the SysAD bus
SysCmd (8:0)	I/O	<b>System command/identifier bus parity:</b> A 9 bit bus for command and data identifier transmission between the processor and an external agent
SysCmdP	I/O	<b>System command /data identifier bus parity:</b> A single, even parity bit for thr SysCmd bus
ValidIn*	I	<b>Valid Input:</b> An external agent asserts ValidIn* when it is driving a valid address or data on the SysAD bus and a valid command or data identifier on the SysCmd bus
ValidOut*	O	<b>Valid Output:</b> The processor asserts ValidOut* when it is driving a valid address or data on the SysAD bus and a valid command or data identifier on the SYSCMD bus
ExtRqst*	I	<b>External Request:</b> An external agent asserts ExtRqst* to request the use of the system interface. The processor grants the request by asserting Release*.
Release*	O	<b>Release Interface:</b> In response to the assertion of ExtRqst*, the processor asserts Release* to signal the requesting device that the system interface is available
RdRdy*	I	<b>Read ready:</b> The external agent asserts RdRdy* to indicate that it can accept processor read, invalidate, or update requests in both overlap and non-overlap mode or can accept a read followed by a potential invalidate or update request in the overlap mode
WrRdy*	I	<b>Write ready:</b> An external agent asserts WrRdy* when it can accept a processor write request
IvdAck*	I	<b>Invalidate acknowledge:</b> An external agent asserts IvdAck* to signal successful completion of a processor invalidate or update request (MC only)
IvdErr*	I	<b>Invalidate error:</b> An external agent asserts InvErr* to signal unsuccessful completion of a processor invalidate or update request (MC only)

## SIGNAL DESCRIPTIONS con't

### Clock/Control Interface Signals

TClock (1:0)	O	<b>Transmit clocks:</b> Two identical transmit clocks that establish the system interface frequency
RClock (1:0)	O	<b>Receive clocks:</b> Two identical receive clocks that establish the system interface frequency
MasterClock	I	<b>Master clock:</b> Master clock input establishes the processor operating frequency
Masterout	O	<b>Master clock out:</b> Master clock output aligned with MasterClock
SyncOut	O	<b>Synchronization clock out:</b> Synchronization clock output must be connected to SyncIn through an interconnect that models the interconnect between MasterOut, TClock, RClock, and the external agent
SyncIn	I	<b>Synchronization clock in:</b> Synchronization clock input
IOOut	O	<b>I/O output:</b> Output slew rate control feedback loop output. Must be connected to IOIn through a delay loop that models the I/O path from the processor to an external agent.
IOIn	I	<b>I/O input:</b> Output slew rate control feedback loop input (see IOOut)
Fault*	O	<b>Fault:</b> The processor asserts Fault to indicate a mismatch output of boundry comparators
VccP	I	<b>Quiet Vcc for the PLL:</b> Quiet Vcc for the internal phase lock loop
VssP	I	<b>Quiet Vss for the PLL:</b> Quiet Vss for the internal phase lock loop
Status(7:0)	O	<b>Status:</b> An 8 bit bus that indicates the current operation status of the processor
VccSense	I/O	<b>Vcc Sense:</b> This is a special pin used for testing and characterization. The voltage at this pin directly shows the behavior of the on chip Vcc.
VssSense	I/O	<b>Vss Sense:</b> VssSense provides a separate, direct connection from the on-chip Vss node to a package pin without attaching to the in-package ground planes. VssSense should be connected to Vss in functional system designs.

## SIGNAL DESCRIPTIONS con't

**Interrupt Interface Signals:** These signals comprise the interface used by external agents to interrupt the R4400 processor

Int (5:1)*	I	<b>Interrupt:</b> Five of six general processor interrupts, bit-wise ORed with bits 5:1 of the interrupt register. This feature available on the R4400PC version only.
Int0*	I	<b>Interrupt:</b> One of six general processor interrupts, bit wise ORed with bit 0 of the interrupt register
NMI*	I	<b>Nonmaskable interrupt:</b> Nonmaskable interrupt ORed with bit 6 of the interrupt register

**Initialization Interface:** These signals comprise the interface by which an external agent initializes the R4400 operating parameters

ColdReset*	I	<b>Cold Reset:</b> This signal must be asserted for a power on reset or a cold reset. The clocks SClock, TClock, and RClock begin to cycle and are synchronized with the de-assertion edge of ColdReset*. ColdReset must be de-asserted synchronously with MasterOut.
ModeClock	O	<b>Boot Mode Clock:</b> Serial boot-mode data clock output at the system clock frequency divided by 256
ModeIn	I	<b>Boot mode data in:</b> Serial boot-mode data input
Reset*	I	<b>Reset:</b> This signal must be asserted for any reset sequence. It may be asserted synchronously or asynchronously for a cold reset, or synchronously to initiate a warm reset. Reset must be de-asserted synchronously with MasterOut.
VccOk	I	<b>Vcc is OK:</b> When asserted, this signal tells the R4400 that the 3.3 Volt power supply has been above 3.15 Volts for more than 100 milliseconds & will remain stable. Assertion of VccOK starts initialization sequence.
256K/1M*	I	<b>Cache size Select:</b> Must be connected to ground to enable the full 1M Byte of cache. Cache size will be 256K if pin is left unconnected.

### JTAG Interface Signals

JTDI	I	<b>JTAG data in:</b> Data is serial, scanned in thru this pin
JTCK	I	<b>JTAG clock input:</b> The processor outputs a serial clock on JTCK. On the rising edge of JTCK, both JTDI and JTMS are sampled.
JTDO	O	<b>JTAG data out:</b> Data is serial, scanned out thru this pin
JTMS	I	<b>JTAG:</b> JTAG command signal indicates that the incoming serial data is command clear

## ACT4431SC – CQFP – PINOUTS

Pin #	Function	Pin #	Function	Pin #	Function
1	TClock 0	48	Vss	95	Vss
2	Vss	49	VssP	96	Sys AD 59
3	Sys AD 45	50	Vcc	97	Vcc
4	Vss	51	IvdAck*	98	Sys AD 27
5	TClock 1	52	Vss	99	Vss
6	Vss	53	VccP	100	IO In
7	Sys AD 13	54	Vcc	101	Vcc
8	Vss	55	Status 5	102	Sys AD 58
9	Sys AD 14	56	Vss	103	Vss
10	Vcc	57	Status 6	104	Sys AD 26
11	JTMS	58	Vcc	105	Vcc
12	Vcc	59	Status 7	106	IO Out
13	Sys AD 46	60	Vcc	107	Vss
14	Vcc	61	Sys ADC 7	108	Sys AD 57
15	JTDO	62	Vcc	109	Vcc
16	Vcc	63	Sys ADC 3	110	Sys AD 25
17	Sys AD 15	64	Vcc	111	Vss
18	Vcc	65	VCC Ok	112	GRPRUN ⚡
19	Sys AD 47	66	Vcc	113	Vcc
20	Vss	67	Sys AD 63	114	Sys AD 56
21	Status 0	68	Vss	115	Vss
22	Vcc	69	MasterOut	116	Sys AD 24
23	JTDI	70	Vss	117	Vcc
24	Vss	71	Sys AD 31	118	GRPSTALL ⚡
25	Sys ADC 1	72	Vcc	119	Vss
26	Vcc	73	Sys AD 30	120	Sys ADC 6
27	Sys ADC 5	74	Vcc	121	Vcc
28	Vcc	75	Sys AD 62	122	Sys ADC 2
29	Status 2	76	Vss	123	Vss
30	Vcc	77	Sync Out	124	NMI*
31	Status 1	78	Vss	125	Vcc
32	Vcc	79	Sys AD 29	126	Sys AD 55
33	JTCK	80	Vss	127	Vss
34	Vss	81	RClock 1	128	Sys AD 23
35	Sync In	82	Vss	129	Vcc
36	Vss	83	Sys AD61	130	Release *
37	Vss Sense	84	Vss	131	Vss
38	Vss	85	RClock 0	132	Sys AD 22
39	Vcc Sense	86	Vss	133	Vcc
40	Vss	87	Vcc	134	Sys AD 54
41	MasterClock	88	Reset*	135	Vss
42	Vss	89	Vcc	136	Mode In
43	Status 3	90	Sys AD 60	137	Vcc
44	Vcc	91	Vss	138	Rd Rdy *
45	IvdErr*	92	Sys AD 28	139	Vss
46	Vcc	93	Vcc	140	Sys AD 53
47	Status 4	94	Cold_Reset*	141	Sys AD 21

⚡ Do not connect, factory test only, ⚡ Connect to +V Volts

## ACT4431SC – CQFP – PINOUTS (con't)

Pin #	Function	Pin #	Function	Pin #	Function
142	Vss	189	Int 4*	236	Vss
143	Ext RQST*	190	Vcc	237	Sys Cmd 3
144	Vcc	191	Int 5*	238	Vcc
145	Sys AD 52	192	Vss	239	Sys AD 7
146	Vss	193	Vcc	240	Vss
147	Valid Out*	194	256K/1M*	241	Sys AD 39
148	Vcc	195	SPARE	242	Vcc
149	Sys AD 20	196	SPARE	243	Sys Cmd 4
150	Vss	197	SPARE	244	Vss
151	Sys AD 19	198	CASE GROUND	245	Sys ADC 0
152	Vcc	199	Vss	246	Vcc
153	Sys AD 51	200	Sys AD 32	247	Sys ADC 4
154	Vss	201	Vcc	248	Vss
155	ValidIn*	202	Sys AD 0	249	Sys Cmd 5
156	Vcc	203	Vss	250	Vcc
157	Sys AD 18	204	Sys AD 1	251	Sys AD 8
158	Vss	205	Vcc	252	Vss
159	Sys AD 50	206	Sys AD 33	253	Sys AD 40
160	Vcc	207	Vss	254	Vcc
161	Int 0*	208	Sys AD 34	255	Sys Cmd 6
162	Vss	209	Vcc	256	Vss
163	Sys AD 49	210	Sys AD 2	257	Sys AD 9
164	Vcc	211	Vss	258	Vcc
165	Sys AD 17	212	Sys Cmd 0	259	Sys AD 41
166	Vss	213	Vcc	260	Vss
167	Sys AD 16	214	Sys AD 35	261	Sys CMD 7
168	Vcc	215	Vss	262	Vcc
169	Sys AD 48	216	Sys AD 3	263	Sys AD 10
170	Vss	217	Vcc	264	Vss
171	SPARE	218	Sys AD 4	265	Sys AD 42
172	SPARE	219	Vss	266	Vcc
173	SPARE	220	Sys Cmd 1	267	Sys Cmd 8
174	SPARE	221	Vcc	268	Vss
175	SPARE	222	Sys AD 36	269	Sys AD 11
176	SPARE	223	Vss	270	Vcc
177	SPARE	224	Sys Cmd 2	271	Sys AD 43
178	Vss	225	Vcc	272	Vss
179	Int 1*	226	Sys AD 5	273	Sys Cmd P
180	Vcc	227	Sys AD 37	274	Vcc
181	Int 2*	228	Vss	275	Sys AD 12
182	Vss	229	Mode Clock	276	Vss
183	SPARE	230	Vcc	277	Sys AD 44
184	SPARE	231	WR RDY*	278	Vcc
185	Int 3*	232	Vss	279	Fault*
186	SPARE	233	Sys AD 6	280	Vss
187	SPARE	234	Vcc		
188	Vss	235	Sys AD 38		

✪ Do not connect, factory test only, ✦ Connect to +V Volts

## ACT4430PC – PGA – PINOUTS

Function	Pin #	Function	Pin #	Function	Pin #	Function	Pin #
Coldreset	T14	SysAD 14	D17	SysAD 59	V15	Vcc	L18
ExtRqst	U2	SysAD 15	E1B	SysAD 60	T15	Vcc	M1
Fault	B16	SysAD 16	K2	SysAD 61	U17	Vcc	N18
Reserved (NC)	U10	SysAD 17	M2	SysAD 62	N16	Vcc	R1
Vcc	T9	Syr.AD 18	Pi	SysAD 63	N17	Vcc	T18
IOIn	T13	SysAD 19	P3	SysADC0	C8	Vcc	U1
IOOut	U12	SysAD 20	T2	SysADC 1	G17	Vcc	V3
Int 0	N2	SysAD 21	T4	SysADC 2	T8	Vcc	V6
Int 1	L3	SysAD 22	U5	SysADC 3	L16	Vcc	V8
Int 2	K3	SysAD 23	U6	SysADC 4	B8	Vcc	V10
Int 3	J3	SysAD 24	U9	SysADC 5	H16	Vcc	V12
Int 4	H3	SysAD 25	U11	SysADC 6	U8	Vcc	V14
Int 5	F2	SysAD 26	T12	SysADC 7	L17	Vcc	V17
JTCK	H17	SysAD 27	U14	SysCmd 0	E2	Vss	A3
JTDI	G16	SysAD 28	U15	SysCmd 1	D3	Vss	A6
JTDO	F16	SysAD 29	T16	SysCmd 2	B2	Vss	A8
JTMS	E16	SysAD 30	R17	SysCmd 3	A5	Vss	A10
MasterClock	J17	SysAD 31	M16	SysCmd 4	B7	Vss	A12
MasterOut	P17	SysAD 32	H2	SysCmd 5	C9	Vss	A14
ModeClock	B4	SysAD 33	G3	SysCmd 6	B10	Vss	A17
ModeIn	U4	SysAD 34	F3	SysCmd 7	B12	Vss	A18
NMI	U7	SysAD 35	D2	SysCmd 8	C13	Vss	B1
PLLCap 0	....	SysAD 36	C3	SysCmd 9	C14	Vss	C18
PLLCap 1	....	SysAD 37	B3	TClock 0	C17	Vss	D1
RClock 0	T17	SysAD 38	C6	TClock 1	D16	Vss	F18
RClock 1	R16	SysAD 39	C7	VCCOk	M17	Vss	GI
RdRdy	T5	SysAD 40	C10	ValidIn	P2	Vss	H18
Release	V5	SysAD 41	C11	ValidOut	R3	Vss	J1
Reset	U16	SysAD 42	B13	WrRdy	C5	Vss	K18
SyncIn	J16	SysAD 43	A15	VccP	K17	Vss	L1
SyncOut	P16	SysAD 44	C15	VssP	K16	Vss	M18
SysAD 0	J2	SysAD 45	B17	Vcc	A2	Vss	N1
SysAD 1	G2	SysAD 46	E17	Vcc	A4	Vss	P18
SysAD 2	E1	SysAD 47	F17	Vcc	A9	Vss	R18
SysAD 3	E3	SysAD 48	L2	Vcc	A11	Vss	T1
SysAD 4	C2	SysAD 49	M3	Vcc	A13	Vss	U18
SysAD 5	C4	SysAD 50	N3	Vcc	A16	Vss	V1
SysAD 6	B5	SysAD 51	R2	Vcc	B18	Vss	V2
SysAD 7	B6	SysAD 52	T3	Vcc	C1	Vss	V4
SysAD 8	B9	SysAD 53	U3	Vcc	D18	Vss	V7
SysAD 9	B11	SysAD 54	T6	Vcc	F1	Vss	V9
SysAD 10	C12	SysAD 55	T7	Vcc	G18	Vss	V11
SysAD 11	B14	SysAD 56	T10	Vcc	H1	Vss	V13
SysAD 12	B15	SysAD 57	T11	Vcc	J18	Vss	V16
SysAD 13	C16	SysAD 58	U13	Vcc	K1	Vss	V18

Package Figure — ACT4431SC — CQFP 280 Leads

“F10” Package

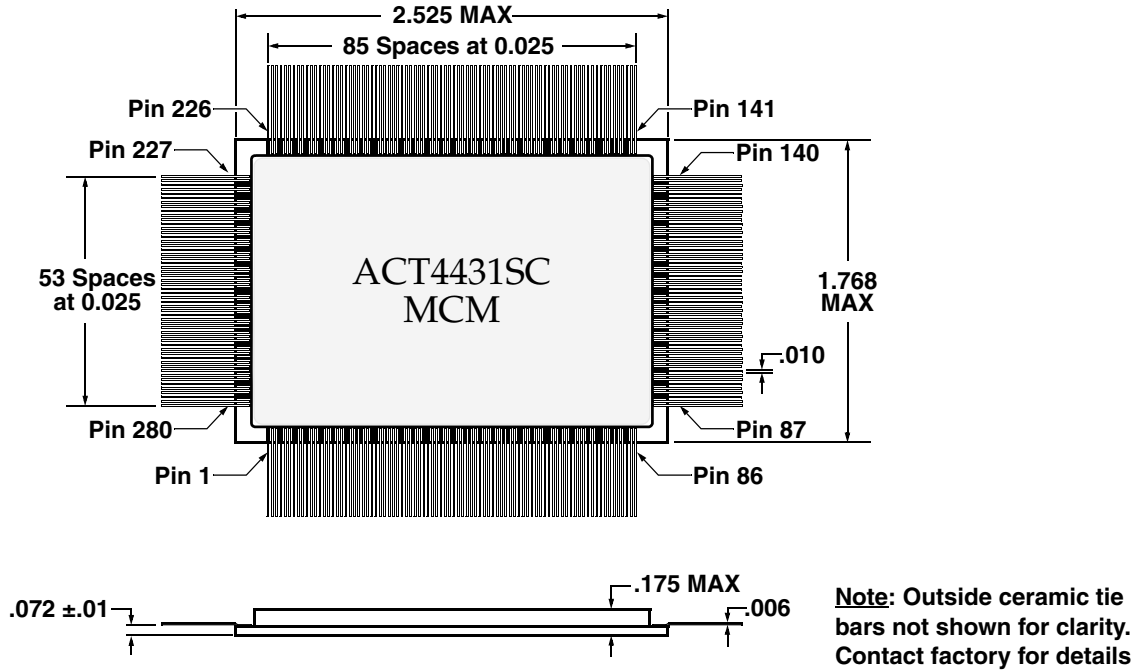

Package Figure — ACT4430PC — PGA 179 Pins

“P10” Package

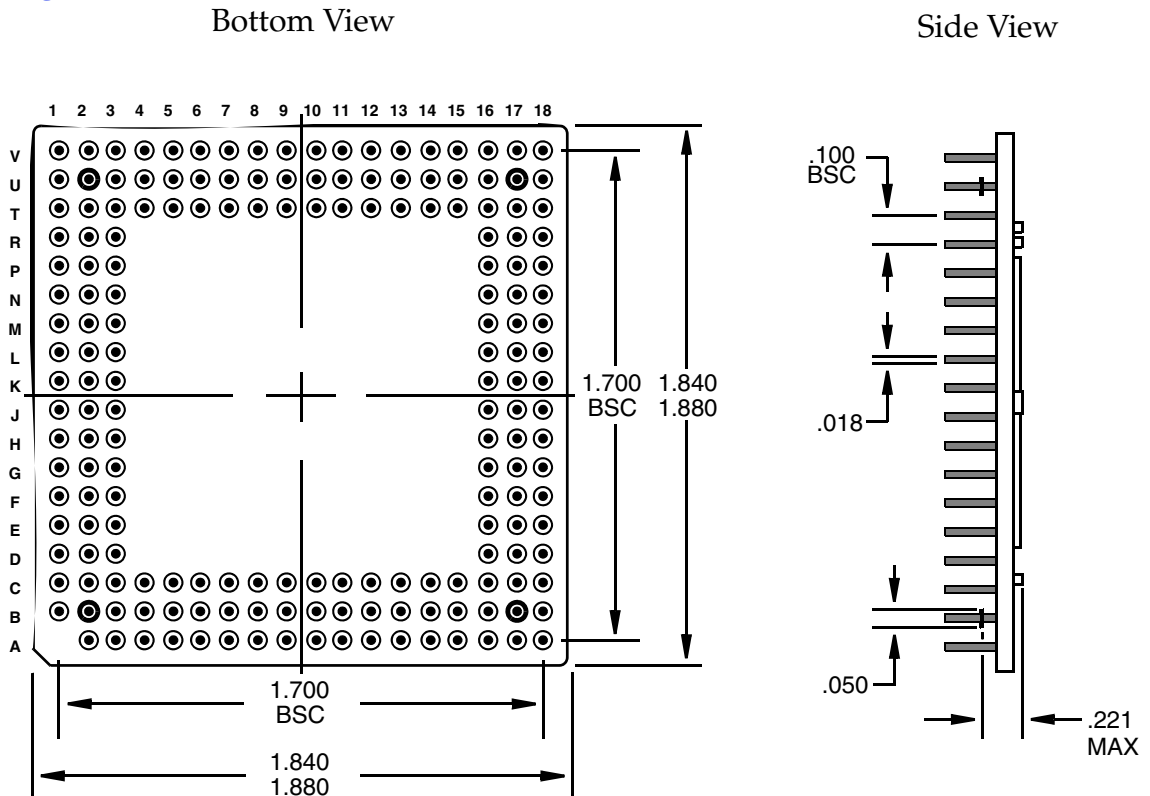

## ORDERING INFORMATION

<b>Microprocessor Module Description</b>	<b>Aeroflex Part Number</b>
ACT4430PC Primary Cache, +3.3 Volt P.S. PGA Package	ACT4430PC P10 MCM
ACT4431SC 1Meg Secondary Cache, +3.3 Volt Flat Package	ACT4431SC 1M F10 MCM

**PLAINVIEW, NEW YORK**  
Toll Free: 800-THE-1553  
Fax: 516-694-6715

**INTERNATIONAL**  
Tel: 805-778-9229  
Fax: 805-778-1980

**NORTHEAST**  
Tel: 603-888-3975  
Fax: 603-888-4585

**SE AND MID-ATLANTIC**  
Tel: 321-951-4164  
Fax: 321-951-4254

**WEST COAST**  
Tel: 949-362-2260  
Fax: 949-362-2266

**CENTRAL**  
Tel: 719-594-8017  
Fax: 719-594-8468

***www.aeroflex.com info-ams@aeroflex.com***

Aeroflex Microelectronic Solutions reserves the right to change at any time without notice the specifications, design, function, or form of its products described herein. All parameters must be validated for each customer's application by engineering. No liability is assumed as a result of use of this product. No patent licenses are implied. All trademarks are acknowledged. Parent company Aeroflex, Inc. 2003.



Our passion for performance is defined by three attributes represented by these three icons: solution-minded, performance-driven and customer-focused