

# Application Note



## Characterizing frequency dividers and multipliers with the 6840 series Microwave System Analyzer



Measurement of multiplier and divider performance using the 6840 series Microwave Systems Analyzer, including conversion and return loss, frequency response, harmonics and sub-harmonics, output power and spurious responses

## Introduction

Frequency dividers and multipliers are key components of modern RF and microwave systems. Their main application is in frequency synthesis.

Dividers and multipliers are generally operated over a band of frequencies, and a common problem is how to measure their performance throughout this range. Traditionally, a separate signal generator and spectrum analyzer are used in an essentially manual operation. This application note shows how the 6800 series microwave system analyzers (MSA) allow automatic measurements of these devices to be performed with a single instrument.

Some general notes on conversion measurements are given, followed by a description of how to measure output power at any harmonic for dividers and multipliers. For clarity, details of some less common measurements are found in the Appendix.

## Conventions

The following conventions are used to indicate keypresses on the MSA.

**[BOLD]** - Hardkey press, i.e. a dedicated front panel function key.

[normal] - data entry via numeric keypad

*[italic]* - Softkey press, i.e. a software menu key.

- - toggle function enabled
- - toggle function disabled

## FREQUENCY CONVERSION MEASUREMENTS USING 6840

The 6840 series has an independent signal generator and spectrum analyzer in one box. Unlike most tracking generators, where the source signal is derived by downconverting the spectrum analyzer LO (local oscillator), the 6840 series can apply any scale and offset to the source with respect to the receiver frequency.

Frequency conversion measurements can be made using the scale / offset tracking generator in spectrum analyzer mode or the tuned input in scalar analyzer mode. Different features are available in the two modes and the best mode to use depends on the application. The following sections describe the two modes.

### Offset tracking generator mode

In offset tracking generator mode, the frequencies are always entered at the receiver frequency range using

**[SPECTRUM]** [Set Start Frequency] /

[Set Stop Frequency] or [Set Cntr Frequency] / [Set Span].

The source frequency is determined by Offset and Scale (under the **[SOURCE]** button). The source frequency is calculated as follows:-

If [Apply Scale then Offset] is selected

$$F_{source} = (F_{receiver} \times scale) + offset$$

If [Apply Offset then Scale] is selected

$$F_{source} = (F_{receiver} + offset) \times scale$$

To use scale alone, press

[Set Offset] [0]

and the above results are the same. Scale and Offset can be positive or negative, which is useful for mixer measurements, and Scale can be a multiple or fraction. The annotation shown on the display and plots can be chosen to be in terms of source or receiver frequency by selecting

**[SPECTRUM]** [More] [X-axis annotation]

The type of annotation is indicated by 'Src' or 'RX' at the bottom left of the display. If the source start or stop frequencies are out of range, "OTG?" appears at the bottom of the screen.

It will be shown later that this mode is ideal for measuring frequency dividers. It also allows the source to be quickly switched back to CW to observe the signal on the spectrum analyzer.

### Offset tracking generator normalization

In tracking generator mode, the **[CAL]** [Normalise] feature can be used to perform a through path calibration. In offset tracking generator mode, the signal undergoes a frequency conversion and no reference signal path is usually available. Normalization cannot therefore be performed in offset tracking generator mode.

This is readily overcome in the 6840 series by firstly normalizing in tracking generator mode, then changing to offset tracking generator mode. The normalization will still be applied to the receiver data, improving the spectrum analyzer accuracy and compensating for loss in the spectrum analyzer cable when using the offset tracking generator.

To perform the normalization, proceed as follows.

**[SPECTRUM]** [Set Start Frequency]/[Set Stop Frequency] or [Set Cntr Frequency]/[Set Span] to set the receiver frequency range that will be used in the offset mode measurement.

[Set Ref Level] enter reference level to be used in offset mode measurement

**[SOURCE]** [Tracking Generator]

[Set Output Power] enter same as spectrum analyzer reference level

**[SOURCE ON/OFF]** ●

**[CAL]** [Normalise]

Use the same cable that will be used to connect the spectrum analyzer to the output of the frequency conversion device. Connect it between source and spectrum analyzer.

[Continue]

Offset tracking generator mode can now be selected. This normalization works because the uncertainties in the source output level are generally smaller than the spectrum analyzer level accuracy. If the frequency range is altered, another normalization operation will be required.

### Scalar analyzer mode - offset tuned input

As an alternative to the offset tracking generator, frequency conversion measurements can be made with the tuned input in scalar

analyzer mode. The same hardware is used as for offset tracking generator, but the software features are different. The major differences when using the offset tuned input rather than offset tracking generator are as follows.

- The frequencies are entered at the source frequency range rather than receiver. This is more convenient in some applications, particularly frequency multipliers.
- The tuned input can be ratioed with scalar channel C. This could, for example, be used to display gain or conversion gain directly.
- The marker facilities are more powerful, with features such as bandwidth search.
- Many of the normal scalar mode functions are also available, such as increasing the number of frequency points.

In scalar analyzer mode, the source frequency is selected using

[SOURCE] [Set Start Frequency] /

[Set Stop Frequency] or [Set Cntr Frequency] / [Set Span].

The scale and offset are selected with [SCALAR] [Conversion Measurements] [Advanced Set-up]. The offset tuned input frequency is calculated as follows:-

If [Apply Scale then Offset] is selected

$$F_{\text{receiver}} = (F_{\text{source}} \times \text{scale}) + \text{offset}$$

If [Apply Offset then Scale] is selected

$$F_{\text{receiver}} = (F_{\text{source}} + \text{offset}) \times \text{scale}$$

Note that this is different from offset tracking generator mode. The display is annotated in receiver frequency and the offset mode is highlighted by "OSrc" at the bottom of the screen.

### Offset tuned input normalization

A through path calibration can be performed over the source or receiver frequency range. The choice depends on the uncertainties at each side of the device under test. For frequency multipliers and dividers, source level uncertainties are generally small enough to be neglected and a calibration over the receiver frequency range is most suitable. To perform the normalization, proceed as follows.

Set up the frequency range and scale as described above.

[SCALAR] [Input Selection] [Tuned Input] [Tuned Input] [Set Operating Signal Level...] Enter the reference level to be used in the offset measurement. This should be larger than the strongest signal applied to the tuned input.

[SOURCE] [Set Output Power...] Enter the same value as the operating signal level.

[SOURCE ON/OFF] ●

[CAL] [Through Cal] [Display Freq Range]

Use the same cable that will be used to connect the spectrum analyzer to the output of the frequency conversion device. Connect it between source and spectrum analyzer.

[Continue]

The divider or multiplier under test can now be connected, and the source output power set as required. The instrument will read decibels with respect to the operating signal level. When the output power is changed, the instrument will display "PC?" (check path calibration) warning that the annotation is no longer conversion gain.

## 1. CHARACTERIZING FREQUENCY DIVIDERS

The following discussion is applicable to static and dynamic digital dividers and parametric frequency dividers. The most commonly measured RF parameters of a frequency divider system are output power and harmonic levels. The 6800 series scalar analyzer mode can be used to measure output power verses frequency using the set-up shown in Figure 1.

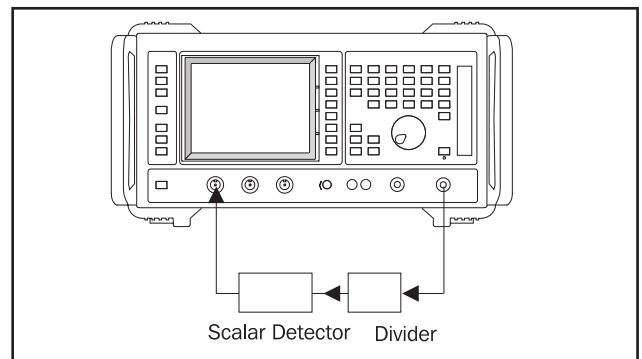

Figure 1 - Using the scalar analyzer to measure divider output power

The scalar detectors are broadband and therefore this system offers no rejection of the high levels of harmonics of the output signal generated by digital dividers. This leads to inaccuracies in the measured output power. Higher accuracy can be achieved using the frequency scaling feature of the 6840 series tracking generator (Figure 2). This has the added benefit of enabling harmonic levels to be measured.

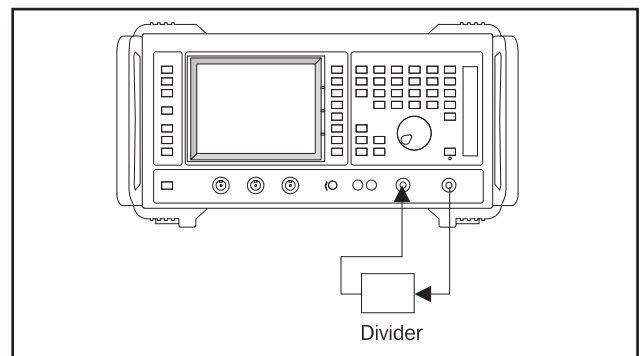

Figure 2: Using the offset/scale tracking generator to measure divider output power and harmonics

It is convenient to use the offset tracking generator mode

because for the first output harmonic, the scaling is simply the divide ratio. The frequency scaling is selected as follows.

$$\text{Scale} = \frac{N}{H}$$

where N is the divide ratio of the divider and H is the required harmonic at the output of the divider. The following settings are suggested.

**[PRESET]** *[Full]*

**[SPECTRUM]** *[Set Cntr Frequency]* enter divider OUTPUT centre frequency

*[Set Span]* enter OUTPUT frequency span (or use start/stop)

Perform a normalization operation if required.

Connect the source to the divider input, spectrum analyzer to the output.

**[SOURCE]** *[Offset Tracking Generator]*

*[Set scale and offset]* *[Set Frequency Scaling]* enter scale value from above equation (N/H)

**[SOURCE ON/OFF]** ●

Note that this method of measuring divider output power makes it very easy to identify regions where the divider stops operating. These regions appear as a 'hole' in the trace. A scalar analyzer may miss these regions, as dividers tend to self oscillate or produce an unstable or noisy signal rather than stop running. Figure 3 shows the measured output power and second harmonic power of a SP8908 divide by 8 device for input frequencies of 800 MHz to 4 GHz. The plots have been overlaid using the memory.

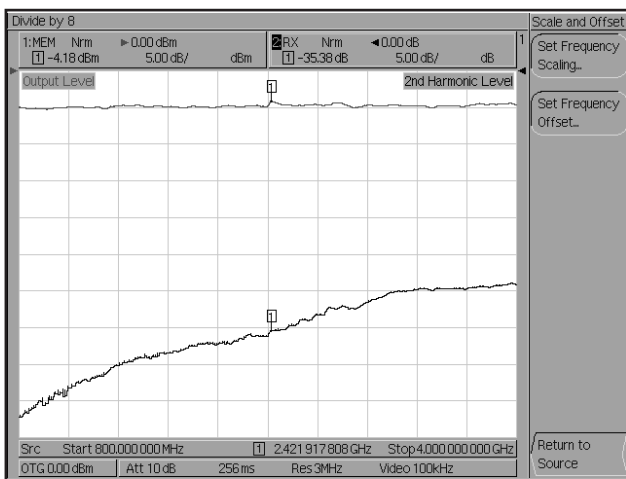

Figure 3: Output power and second harmonic power of SP8908 divider

As an alternative to the offset tracking generator, the scalar analyzer offset tuned input mode can be used to perform swept measurements on frequency dividers. The required scaling is

H/N.

The 6840 series can also be used to measure the input and output return loss of a frequency divider. These measurements are described in the Appendix.

## 2. CHARACTERIZING FREQUENCY MULTIPLIERS

Frequency multipliers and comb generators are commonly characterized by the levels of the various output harmonics for a given drive level. The unwanted harmonic levels of an unfiltered comb generator are so high that useful measurements with a scalar analyzer are not possible. As with frequency dividers, the frequency scaling mode of the 6840 series can be used to pick out the harmonic of interest. This method can also be used to plot the frequency dependency of harmonics on the output of an amplifier.

It is most convenient to use the offset tuned input in scalar analyzer mode because the required scale is simply the harmonic number.

The following measurement procedure is suggested.

**[PRESET]** *[Full]*

**[SCALARI]** *[Yes]* *[Input Selection]* *[Tuned Input]* *[Tuned Input]*

**[SOURCE]** *[Set Start Frequency]* enter multiplier INPUT start frequency

*[Set Stop Frequency]* enter INPUT stop frequency (or use center/span)

*[Set output power]* enter required multiplier input level

**[SCALARI]** *[Conversion Measurements]* *[Advanced Set-up]* *[Apply Scale / Offset]* ●

*[Set Frequency Scaling...]* Enter harmonic number

**[SOURCE ON/OFF]** ●

Perform a normalization operation if required

Connect the source to the multiplier input, spectrum analyzer to the output.

It is important to use a source with low levels of harmonics to test frequency multipliers, or the source harmonics may combine with those generated in the multiplier resulting in a rippled trace. The 6840 has superb harmonic performance (<-55 dBc above 70 MHz), but care should be taken if using an external amplifier to drive the multiplier.

The following example shows a measurement carried out on the circuit of Figure 4.

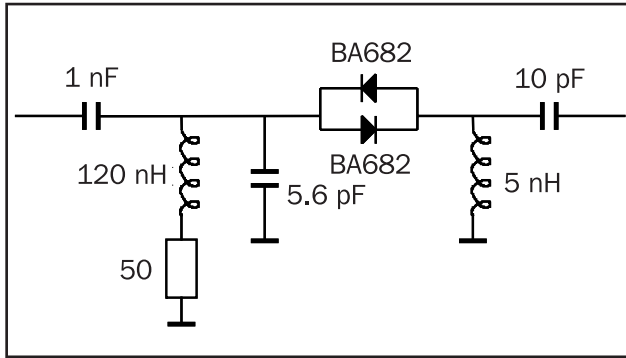

Figure 4: Simple odd harmonic generator

This comb generator produces a signal rich in odd harmonics and suppresses the even harmonics. Figure 5 shows a dual channel measurement of 2nd and 3rd harmonic power made with the 6840. The input frequency is 400 to 500 MHz. Note that as these measurements are updated live, the circuit could be adjusted in real time. The channels are swept alternately.

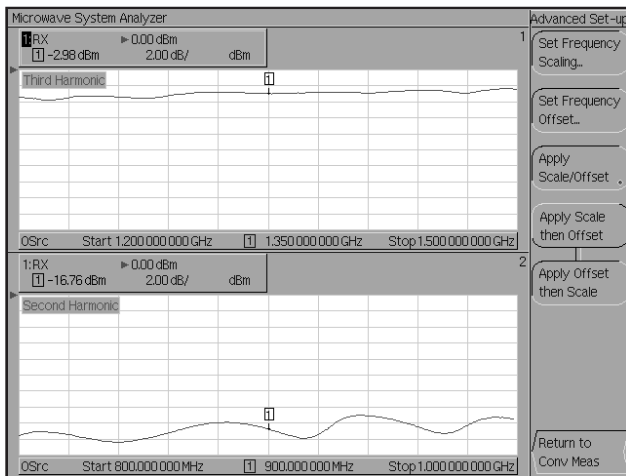

Figure 5: Comparison of 2nd and 3rd harmonic of odd harmonic generator circuit

The offset tracking generator in spectrum analyzer mode can also be used to characterize multipliers. The required scale factor is then the reciprocal of the harmonic number.

It is possible to simultaneously perform two different types of measurement using dual channel mode. For example, one channel can display a spectrum measurement with the source set to CW, and the other a conversion measurement with the source sweeping. Figure 6 shows an example of this measurement for a frequency multiplier.

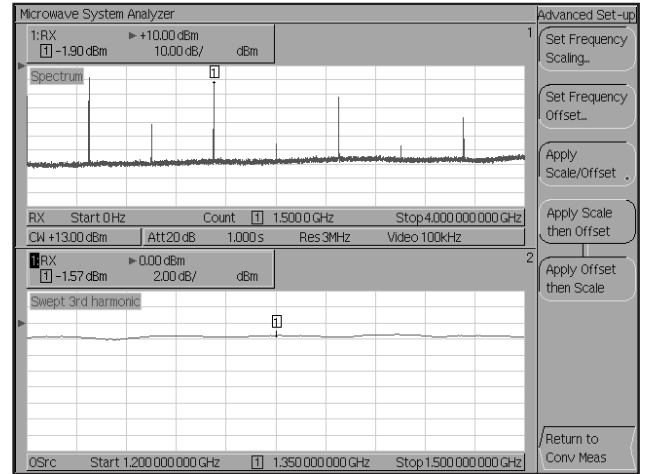

Figure 6: A dual channel spectrum and conversion measurement on a frequency multiplier

To perform a dual channel measurement, use the following procedure.

**[PRESET] [Full]**

Set up the first channel as required. In the example this is a spectrum analyzer with the source set to CW.

**[SWITCH CHANNEL]**

Set up the second channel as required. In the example, an offset tuned input measurement in scalar mode.

Now display both measurements with **[DISPLAY] [Dual Channel Display]**

The channels will now be serviced alternately. To mirror changes to settings on the other channel, enable [channel coupling] in the **[DISPLAY]** menu.

**CONCLUSION**

The most common measurement performed on frequency dividers and multipliers is output power at various harmonics. This Application Note has demonstrated the ease with which such measurements can be made with the 6840 series microwave system analyzer.

In this application, the instrument is faster and more convenient than using a separate signal generator and spectrum analyzer. It is also superior to using a scalar analyzer as the scale and offset tracking generator mode can be used to reject unwanted harmonics.

**APPENDIX A: MEASURING DIVIDER AND MULTIPLIER INPUT RETURN LOSS USING AN AUTOTESTER**

A return loss bridge ("autotester") can be used in the normal way to measure the input match of frequency dividers and multipliers.

First, connect the autotester to the source and scalar input A and calibrate it as follows:-

**[PRESET] [Full]**

**[SCALAR] [yes]**

**[SOURCE]** *[Set Start Frequency]* Enter required value

**[Set Stop Frequency]** Enter required value

**[SOURCE]** *[Set Output Power]* Enter level required at divider/multiplier +6 dB (usual loss of autotester)

**[SOURCE ON/OFF]** ●

**[CAL]** *[Short and Open Cal]*

Connect the calibration pieces as directed by the instrument.

Now connect the divider / multiplier as shown in Figure 7. The return loss will be displayed.

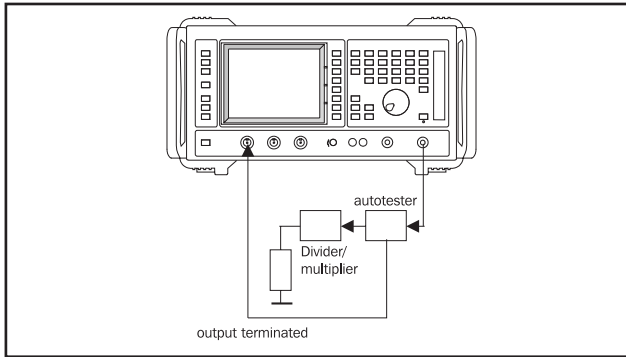

Figure 7: Measuring input return loss

Note that high levels of harmonic / subharmonic backfire from the device under test can spoil the accuracy of this measurement.

**APPENDIX B: MEASURING DIVIDER AND MULTIPLIER OUTPUT RETURN LOSS USING A DIRECTIONAL COUPLER AND A SLIDING SHORT CIRCUIT**

Output return loss of multipliers and dividers can be measured at a spot frequency with the aid of a directional coupler and sliding short circuit. The sliding short needs to have a range of at least half a wavelength at the frequency of interest. The coupler needs to have good directivity otherwise the accuracy is poor (see Table 1).

Table 1: Effect of coupler directivity on output VSWR uncertainty

Coupler directivity	Uncertainty in VSWR
20 dB	22%
30 dB	6.5%
40 dB	2%

In general, the coupler directivity needs to be 10 to 20 dB better than the output return loss being measured.

The spectrum analyzer is used to measure the signal level, such that unwanted harmonics are rejected. Connect the divider/multiplier as shown in Figure 8.

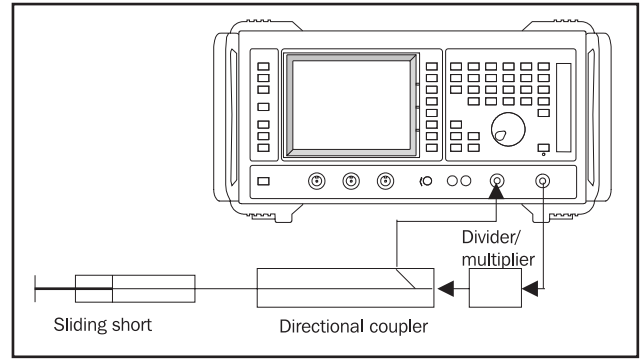

Figure 8: Measuring output match

Enter the following keypresses.

**[PRESET]** *[Full]*

**[SPECTRUM]** *[Set Cntr Frequency]* enter OUTPUT frequency of interest

*[Set Span]* 10 MHz (for example)

**[SOURCE]** *[Set Frequency]* enter input frequency

*[Set Output Power]* enter drive level to the device under test

**[SOURCE ON/OFF]** ●

Observe the coupled signal level. By adjusting the sliding short, find the difference in dB between the maximum and minimum signal level. Call this dB ripple, and calculate the VSWR (voltage standing wave ratio) as follows.

$$V = 10^{\frac{dB\ ripple}{20}}$$

The output return loss is then given by

$$RL = -20 \log \left[ \frac{v-1}{v+2} \right] - 2L \text{ dB}$$

where L is the insertion loss in dB of the coupler at the frequency of interest.

For the very latest specifications visit [www.aeroflex.com](http://www.aeroflex.com)

**CHINA Beijing**

Tel: [+86] (10) 6467 2716  
Fax: [+86] (10) 6467 2821

**CHINA Shanghai**

Tel: [+86] (21) 6282 8001  
Fax: [+86] (21) 62828 8002

**FINLAND**

Tel: [+358] (9) 2709 5541  
Fax: [+358] (9) 804 2441

**FRANCE**

Tel: [+33] 1 60 79 96 00  
Fax: [+33] 1 60 77 69 22

**GERMANY**

Tel: [+49] 8131 2926-0  
Fax: [+49] 8131 2926-130

**HONG KONG**

Tel: [+852] 2832 7988  
Fax: [+852] 2834 5364

**INDIA**

Tel: [+91] 80 5115 4501  
Fax: [+91] 80 5115 4502

**KOREA**

Tel: [+82] (2) 3424 2719  
Fax: [+82] (2) 3424 8620

**SCANDINAVIA**

Tel: [+45] 9614 0045  
Fax: [+45] 9614 0047

**SPAIN**

Tel: [+34] (91) 640 11 34  
Fax: [+34] (91) 640 06 40

**UK Burnham**

Tel: [+44] (0) 1628 604455  
Fax: [+44] (0) 1628 662017

**UK Stevenage**

Tel: [+44] (0) 1438 742200  
Fax: [+44] (0) 1438 727601  
Freephone: 0800 282388

**USA**

Tel: [+1] (316) 522 4981  
Fax: [+1] (316) 522 1360  
Toll Free: 800 835 2352

As we are always seeking to improve our products, the information in this document gives only a general indication of the product capacity, performance and suitability, none of which shall form part of any contract. We reserve the right to make design changes without notice. All trademarks are acknowledged. Parent company Aeroflex, Inc. ©Aeroflex 2005.

[www.aeroflex.com](http://www.aeroflex.com)  
[info-test@aeroflex.com](mailto:info-test@aeroflex.com)



Our passion for performance is defined by three attributes represented by these three icons: solution-minded, performance-driven and customer-focused.

Part No. 46891/847, Issue 1, 07/03